

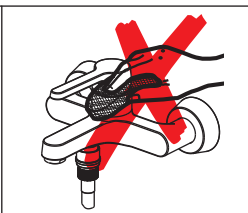

Ricambi / Spare parts

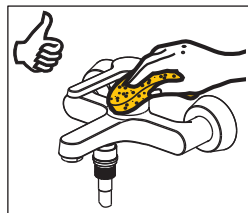
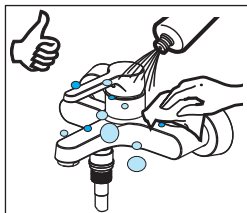
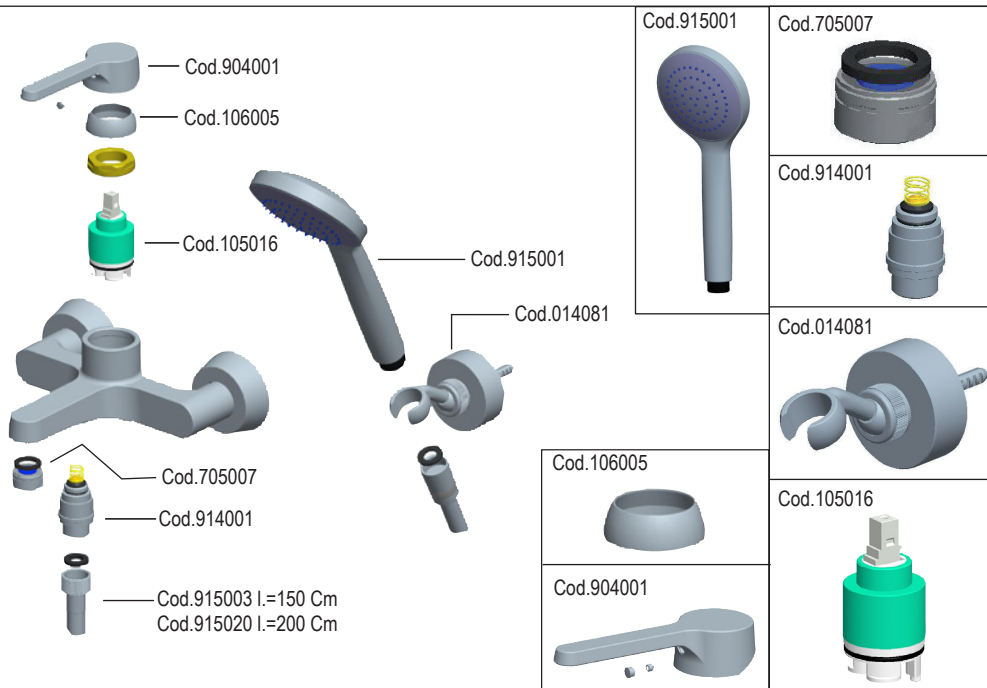

MANUTENZIONE E PULIZIA

Per una corretta manutenzione e pulizia di questo prodotto, raccomandiamo alcuni semplici accorgimenti:

- Utilizzare **detergenti neutri**, spruzzando il prodotto direttamente su un panno morbido onde evitare infiltrazioni
- Evitare **sempre** il contatto con prodotti acidi o abrasivi
- **Risciacquare bene** con abbondante acqua per eliminare eventuali residui ed asciugare sempre con un panno morbido
- Effettuare una **pulizia periodica** al fine di prevenire le formazioni calcaree

La BELLOSTA CARLO & C. non è RESPONSABILE di danni derivati dall'utilizzo di prodotti impropri per la pulizia.

MADE IN ITALY

Questo prodotto è stato realizzato interamente in Italia con l'utilizzo di materie prime di altissima qualità

DESIGN
Piet Billekens

MAINTENANCE AND CLEANING

For a proper maintenance and cleaning, we recommend the following:

- Use **natural detergents**, avoiding to spray directly on taps to avoid residual infiltration
- **Avoid** contact with acid or abrasive products
- **Rinse** with water and **always dry** with a clean cloth to avoid residue of detergent
- Perform a **periodic cleaning** to prevent limestone deposits

BELLOSTA CARLO & C. cannot be held responsible for damages due to an improper use of detergents.

MADE IN ITALY

This product has been entirely manufactured in Italy, by top quality raw materials.



Engineered by POLITEKNE - 07105 ISO 9001-2000 - SCQ

ELITE

DESIGN Piet Billekens

Istruzioni di installazione / Installation instruction

Art.:9001

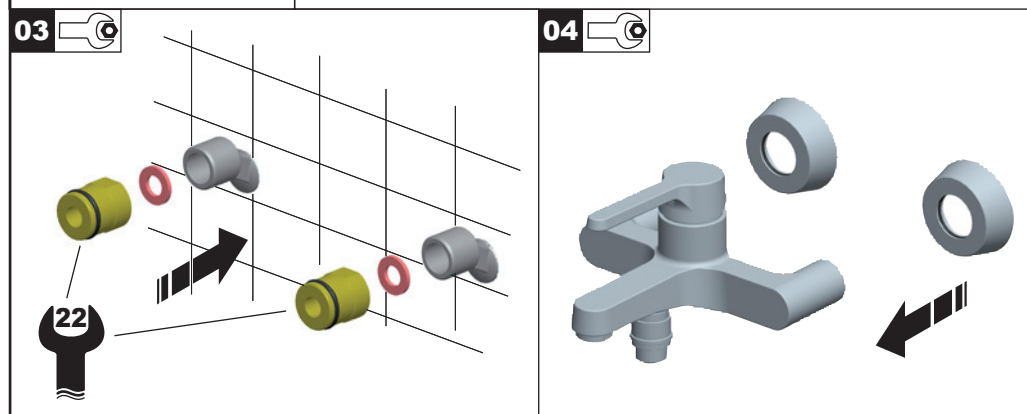
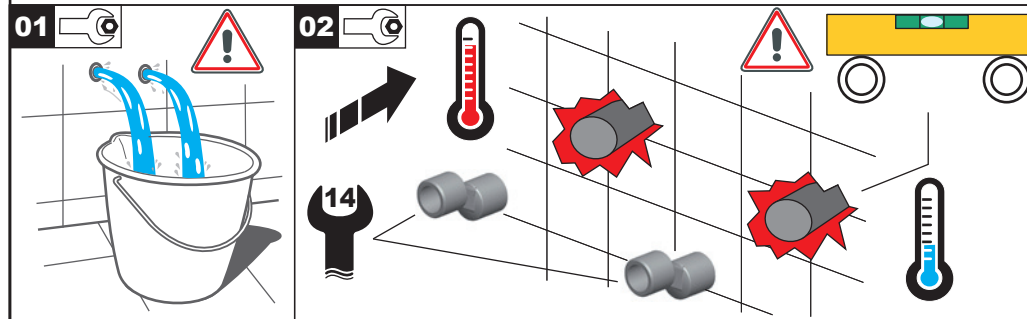

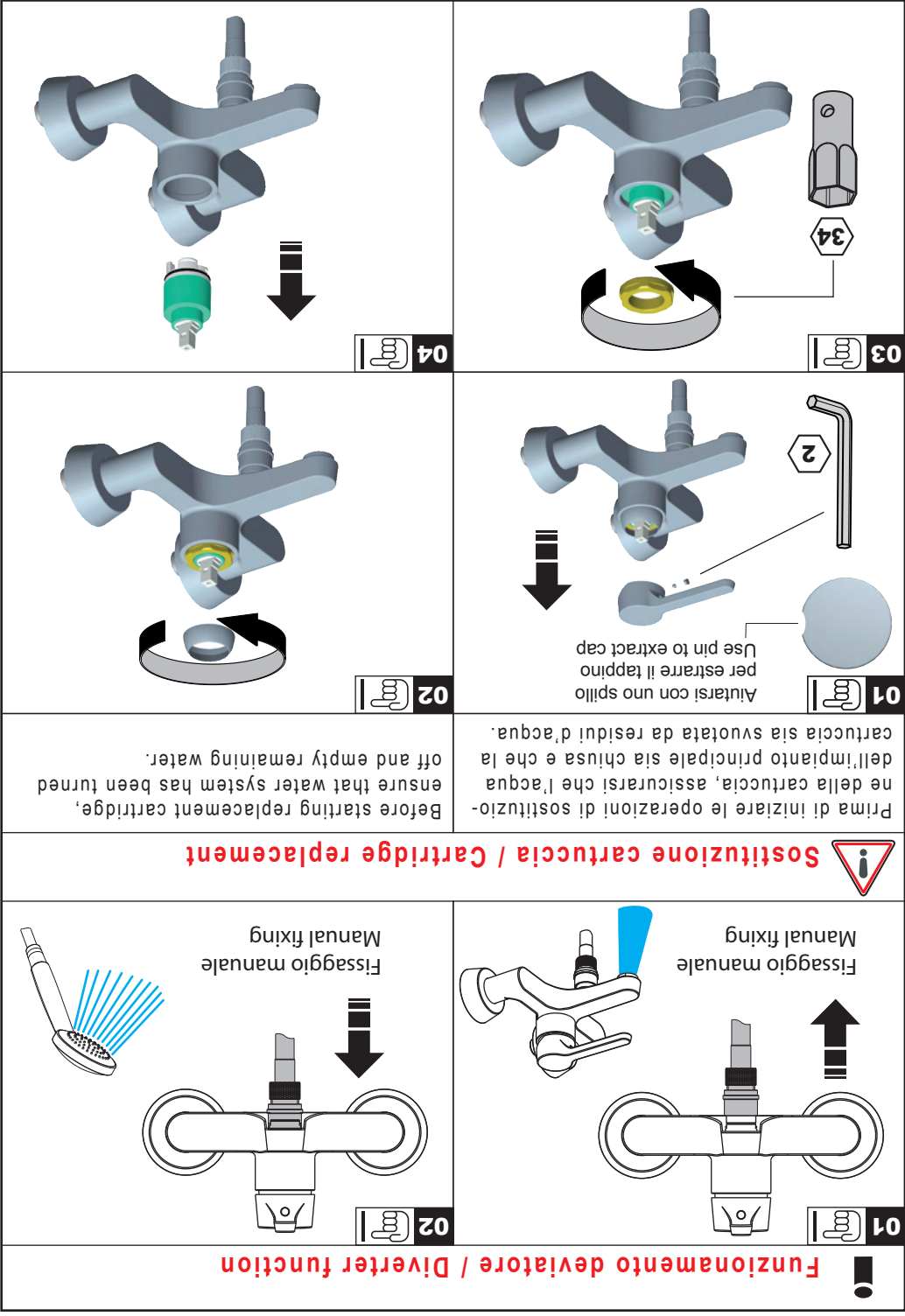
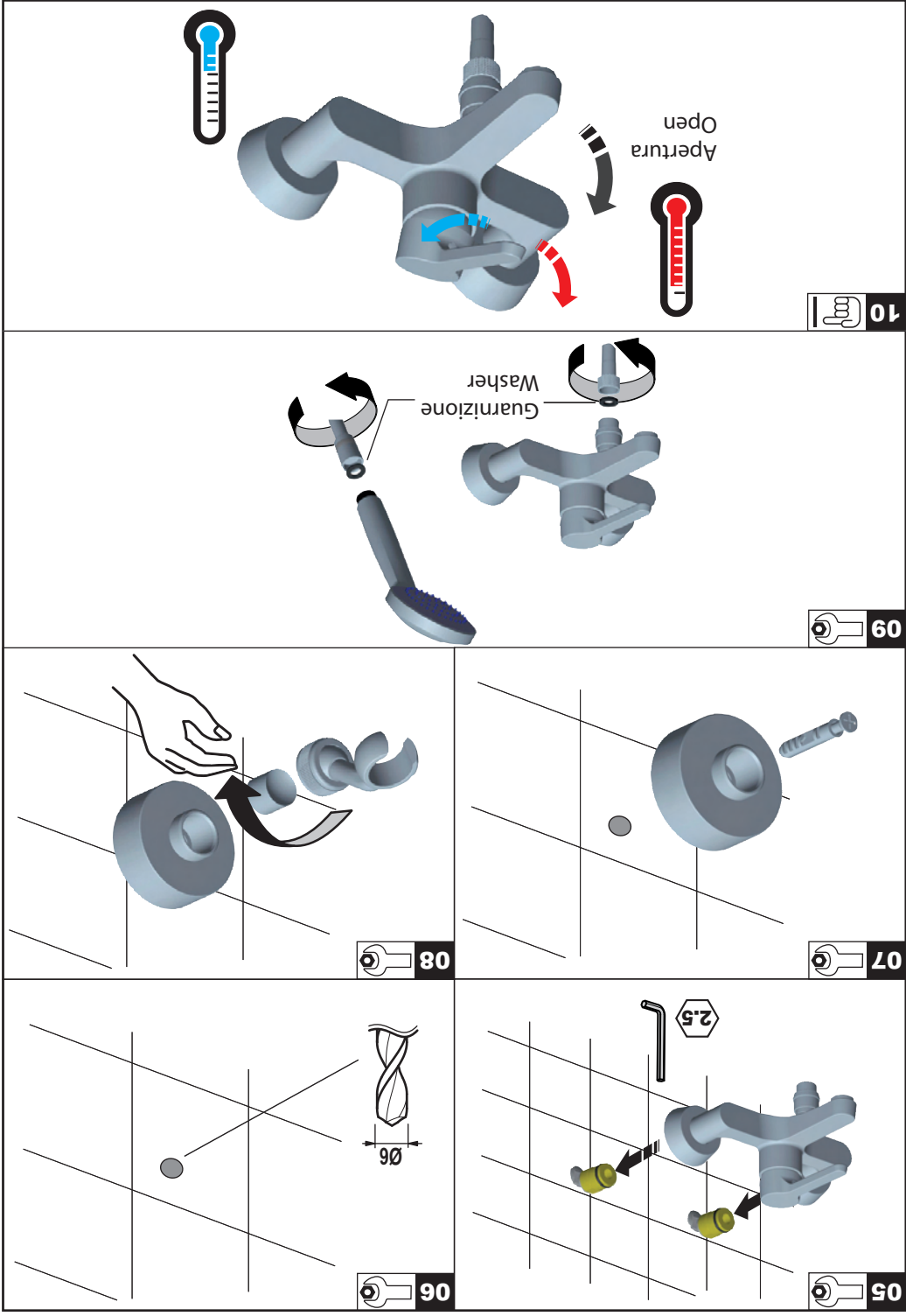

Sostituzione cartuccia / Cartridge replacement

Prima di iniziare le operazioni di sostituzione della cartuccia, assicurarsi che l'acqua ne dell'impianto principale sia chiusa e che la cartuccia sia svuotata da residui d'acqua.

Before starting replacement cartridge, ensure that water system has been turned off and empty remaining water.

Funzionamento deviatore / Diverter function

01 **Fissaggio manuale**
Manual fixing

02 **Fissaggio manuale**
Manual fixing

