

RICAMBI / SPARE PARTS

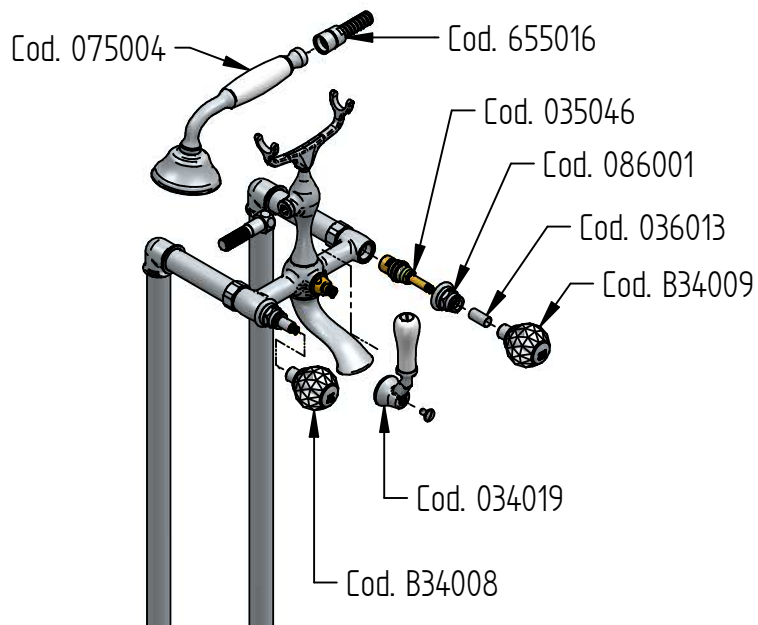

COD. 036013 	COD. B34008
COD. 075004 	COD. B34009
COD. 655016 	COD. 086001
COD. 035046 	COD. 034019

via montenapoleone

Istruzioni di installazione / Installation instruction

art. B3-095



1 IMPORTANTISSIMO



Per installatore: Al fine di garantire la durata del prodotto installare rubinetti con filtro da pulire periodicamente. Effettuare risciacquo delle tubazioni prima di installare il prodotto (PUNTO 1). Eventuali residui se finissero all'interno della cartuccia potrebbero causarne il danneggiamento

For installer: In order to guarantee a long duration of the product install valves with filter, which have to be regularly cleaned (POINT 1). Carry out the rinsing of the pipes before install the tap. Some external materials may damage the cadrige if not removed before the installation.

PAVIMENTO/ FLOOR

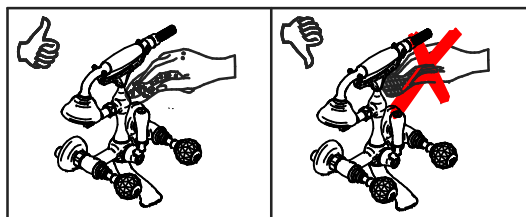
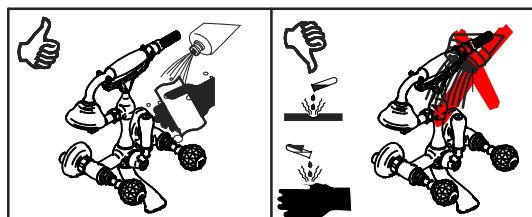
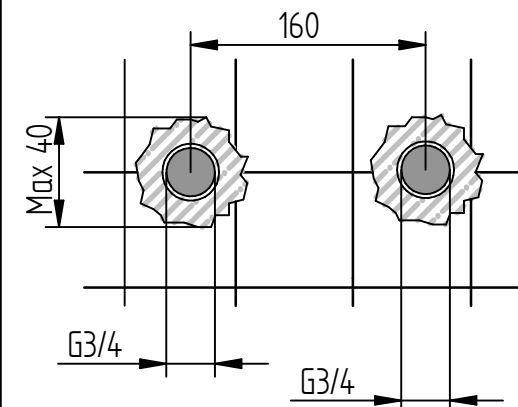

MANUTENZIONE E PULIZIA

Per una corretta manutenzione e pulizia di questo prodotto, raccomandiamo alcuni semplici accorgimenti:

- Utilizzare **detergenti neutri**, spruzzando il prodotto direttamente su un panno morbido onde evitare infiltrazioni
- Evitare **sempre** il contatto con prodotti acidi o abrasivi
- **Risciacquare bene** con abbondante acqua per eliminare eventuali residui ed **asciugare sempre** con un panno morbido
- Effettuare una **pulizia periodica** al fine di prevenire le formazioni calcaree

La BELLOSTA CARLO & C. non è RESPONSABILE di danni derivati dall'utilizzo di prodotti impropri per la pulizia.

MAINTENANCE AND CLEANING

For a proper maintenance and cleaning, we recommend the following:

- Use **neutral detergents**, avoiding to spray directly on taps to avoid residual infiltration
- **Avoid** contact with acid or abrasive products
- **Rinse** with water and **always dry** with a clean cloth to avoid residue of detergent
- Perform a **periodic cleaning** to prevent limestone deposits

BELLOSTA CARLO & C. cannot be held responsible for damages due to an improper use of detergents

ufficio tecnico BELLOSTA
C.A. 10/18 ISO 9001:2015



MADE IN ITALY

Questo prodotto è stato realizzato interamente in Italia con l'utilizzo di materie prime di altissima qualità

DESIGN EOB

MADE IN ITALY

This product has been entirely manufactured in Italy, by top quality raw materials.



Rubinetti d'autore dedicati a te

2

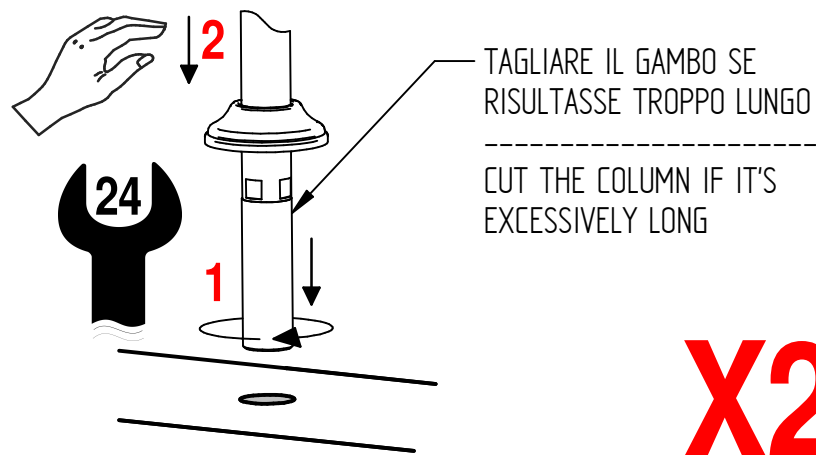

X2

3

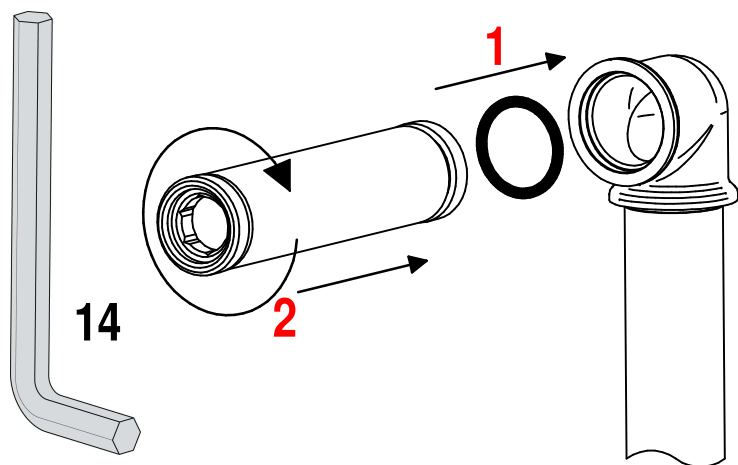

X2

4

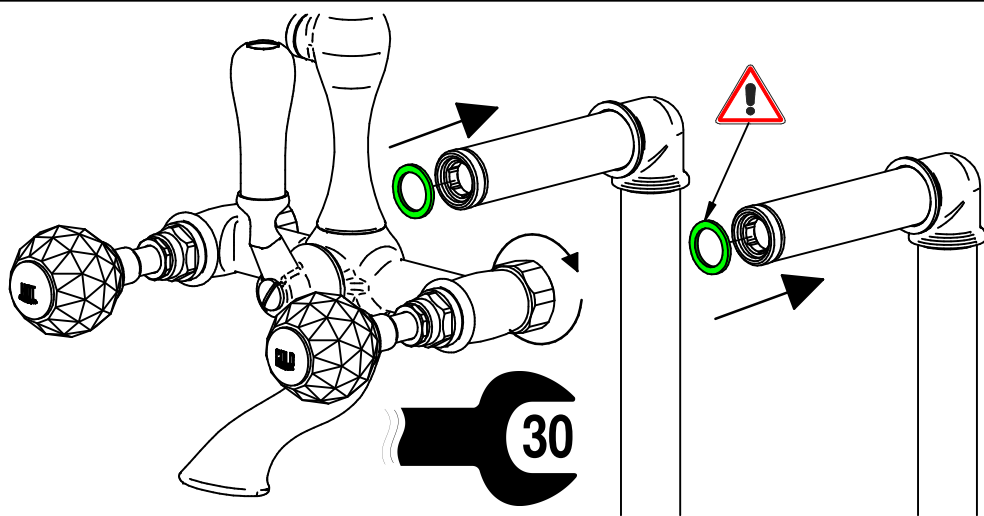

SOSTITUZIONE VITONE / VALVE REPLACEMENT

Prima di iniziare le operazioni di sostituzione del vitone assicurarsi che l'acqua dell'impianto principale sia chiusa.

Before starting replacement of the valve, ensure that water system has been turned off and empty remaining water.

1

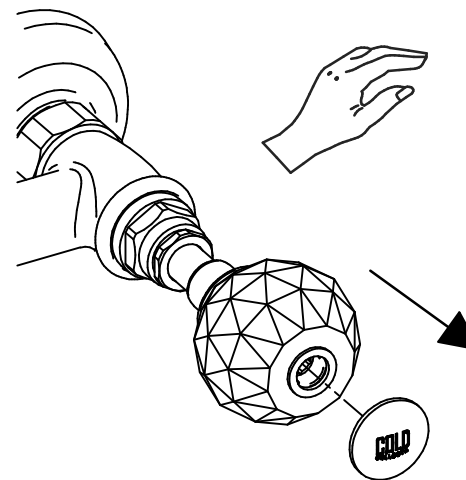

2

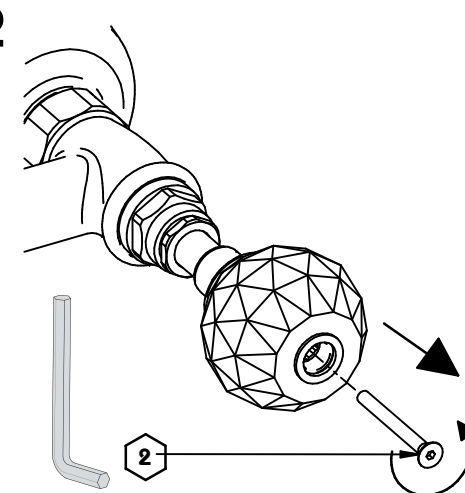

3

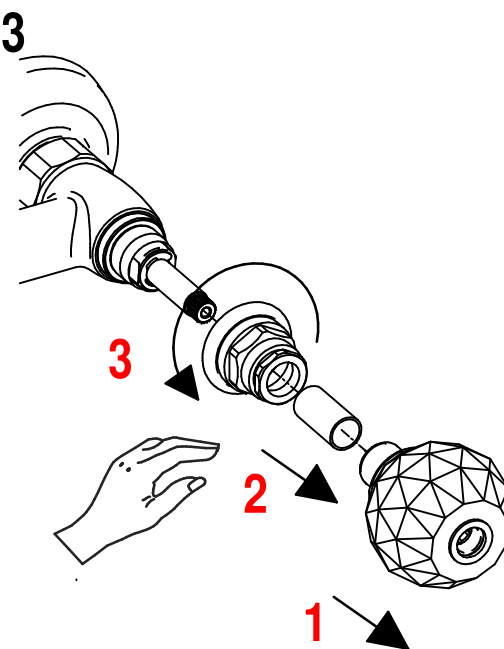

4

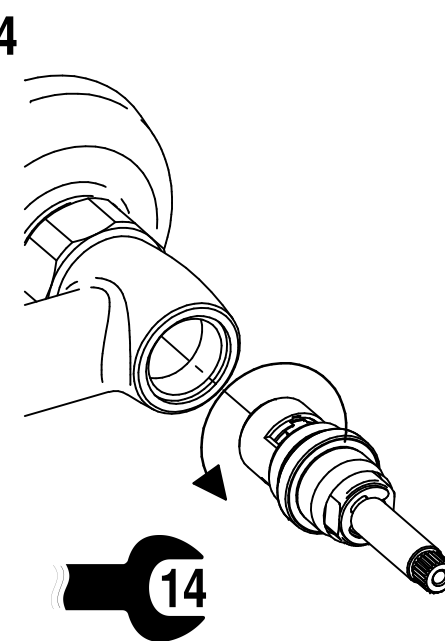

Per qualsiasi richiesta di informazioni, preghiamo contattare l'Ufficio Tecnico presso: info@bellostarubinetterie.com

For any technical inquiries, please contact the Technical Office at: info@bellostarubinetterie.com

B