

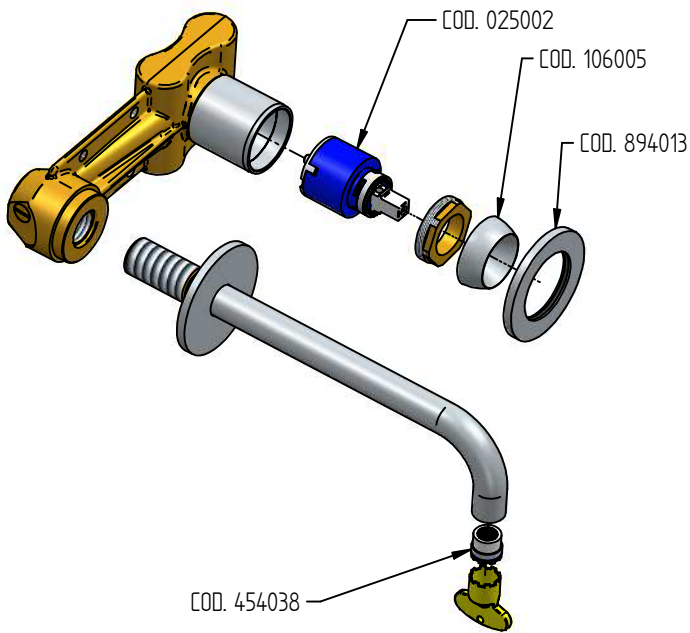

RICAMBI / SPARE PARTS

Plisset Diamond

ISTRUZIONI DI INSTALLAZIONE / INSTALLATION INSTRUCTION



COD. 106005 	COD. 454038 
COD. 894013 	COD. 025002 
	COD. 464017 



Art. 4205/3/B/E

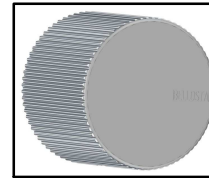

Art. 424002

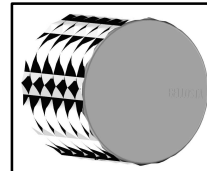

Art. 434002

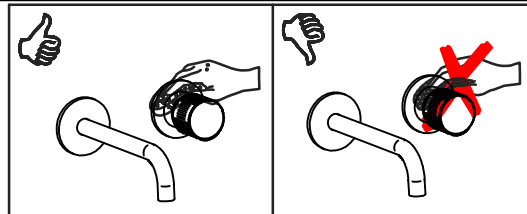
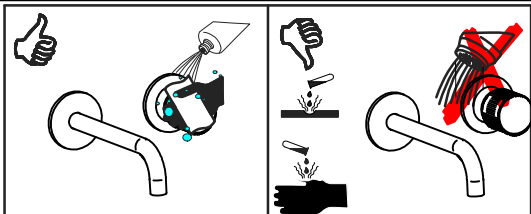

MANUTENZIONE E PULIZIA

Per una corretta manutenzione e pulizia di questo prodotto, raccomandiamo alcuni semplici accorgimenti:

- Utilizzare **detergenti neutri**, spruzzando il prodotto direttamente su un panno morbido onde evitare infiltrazioni
- Evitare **sempre** il contatto con prodotti acidi o abrasivi
- **Risciacquare bene** con abbondante acqua per eliminare eventuali residui ed **asciugare sempre** con un panno morbido
- Effettuare una **pulizia periodica** al fine di prevenire le formazioni calcaree

La BELLOSTA CARLO & C. non è RESPONSABILE di danni derivati dall'utilizzo di prodotti impropri per la pulizia.

MAINTENANCE AND CLEANING

For a proper maintenance and cleaning, we recommend the following:

- Use **neutral detergents**, avoiding to spray directly on taps to avoid residual infiltration
- **Avoid** contact with acid or abrasive products
- **Rinse** with water and **always dry** with a clean cloth to avoid residue of detergent
- Perform a **periodic cleaning** to prevent limestone deposits

BELLOSTA CARLO & C. cannot be held responsible for damages due to an improper use of detergents

**PER INSTALLAZIONE INCASSO VEDI ISTRUZIONI 894001
FOR BUILT-IN PARTS, SEE INSTRUCTIONS 894001**



1
IMPORTANTISSIMO



**Controllo impianto
Plant check**

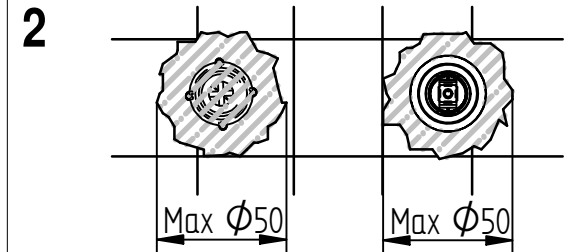

2

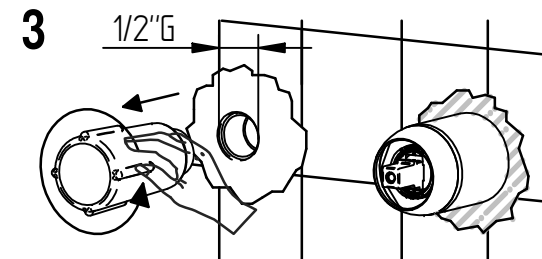

3

ufficio tecnico BELLOSTA
G.G. 07/22 ISO 9001:2015



SCEsm 001

9001-2015 I

socio sostenitore

associato

MADE IN ITALY

Questo prodotto è stato realizzato interamente in Italia con l'utilizzo di materie prime di altissima qualità

**DESIGN
EQB**

MADE IN ITALY

This product has been entirely manufactured in Italy, by top quality raw materials.



Rubinetti d'autore dedicati a te

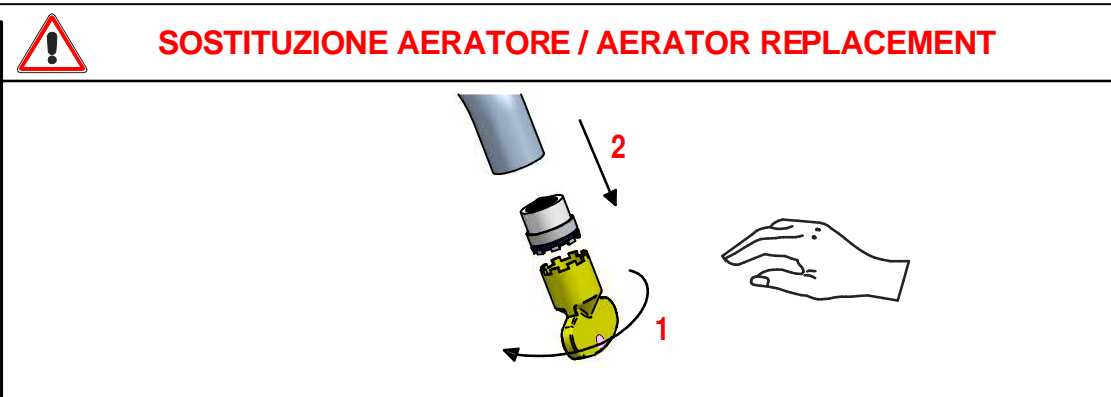
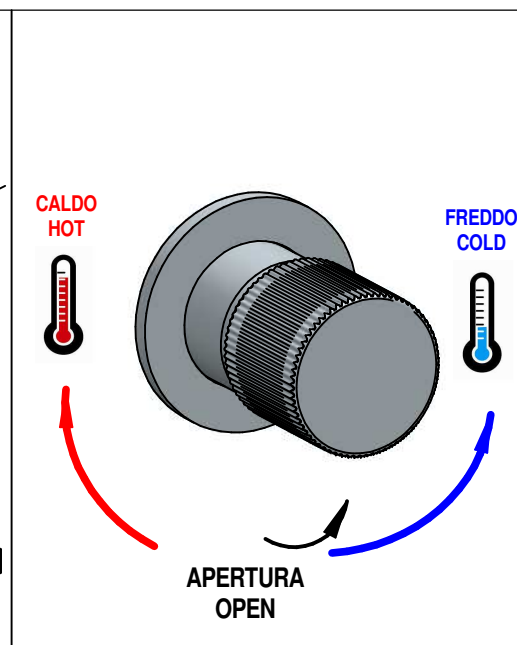
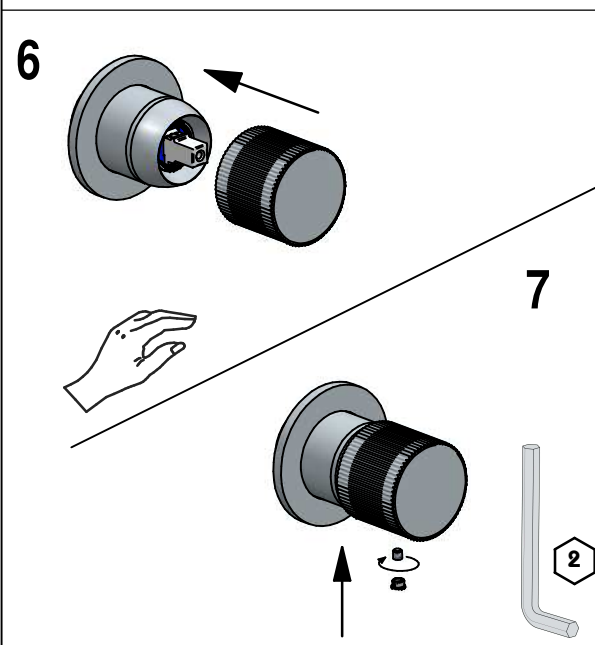
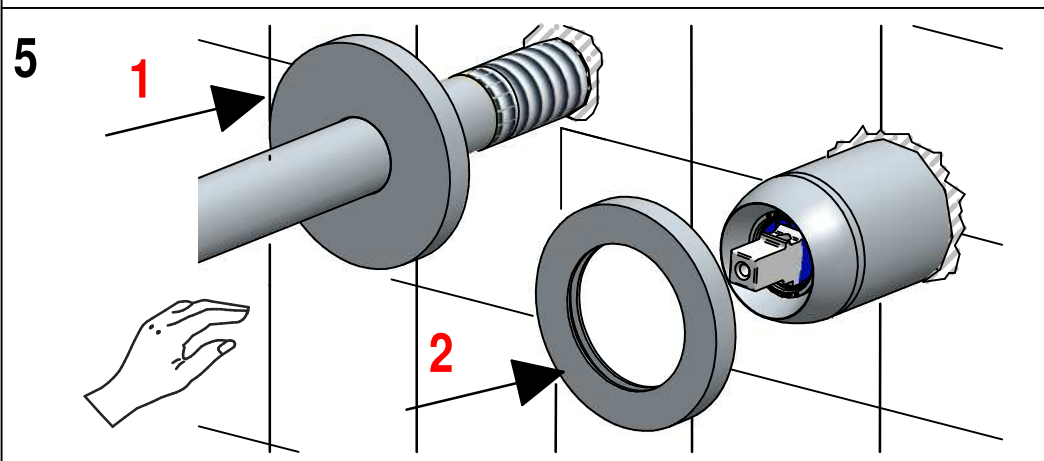
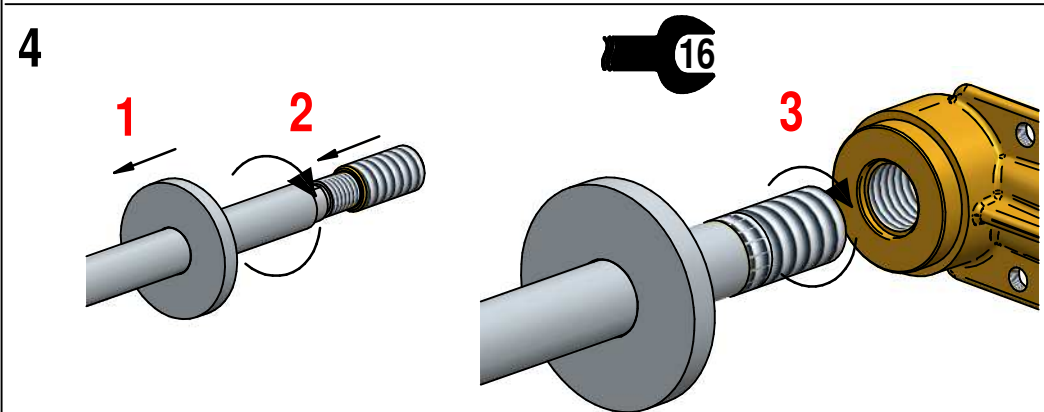

! SOSTITUZIONE CARTUCCIA / CARTRIDGE REPLACEMENT

Prima di iniziare le operazioni di sostituzione della cartuccia assicurarsi che l'acqua dell'impianto principale sia chiusa e che la cartuccia sia svuotata da residui di acqua.

Before starting replacement of cartridge, ensure that water system has been turned off and empty remaining water.

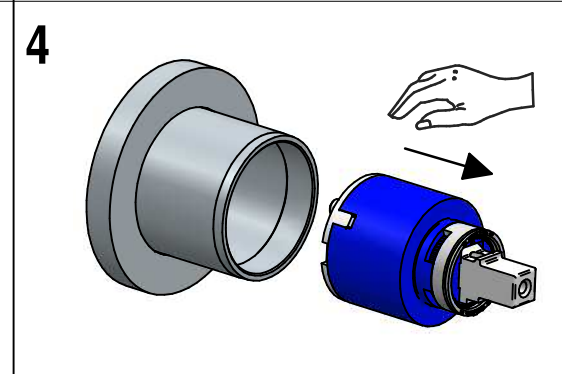
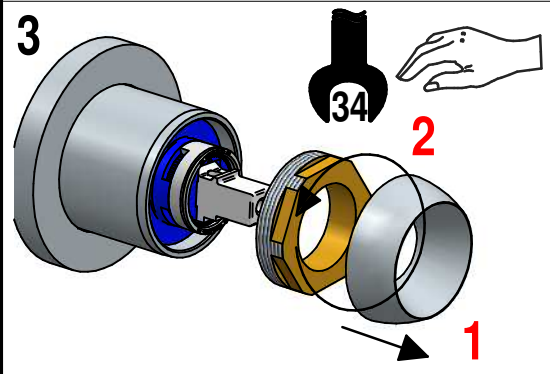
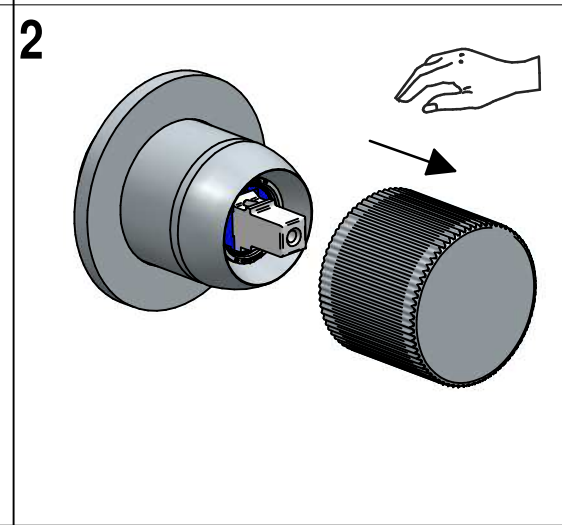
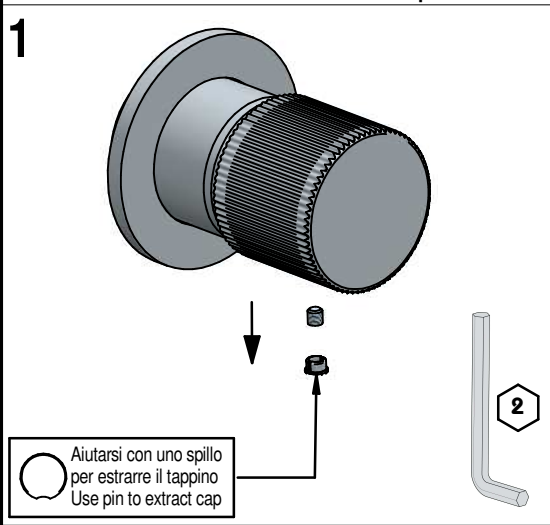

Per qualsiasi richiesta di informazioni, preghiamo contattare l'Ufficio Tecnico presso:
info@bellostarubinetterie.com
 For any technical inquiries, please contact the Technical Office at: info@bellostarubinetterie.com