

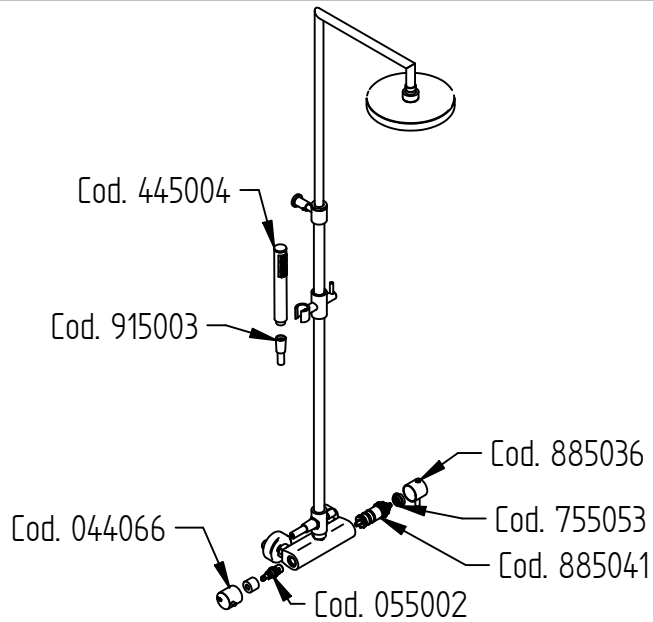





RICAMBI / SPARE PARTS

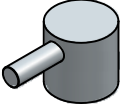

COD. 055002 	COD. 885041 
COD. 044066 	COD. 885036 
COD. 0445004 	COD. 755053 
COD. 915003 	

REVIVRE BLUE

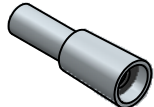
ISTRUZIONI DI INSTALLAZIONE / INSTALLATION INSTRUCTION

ART. 1211/5A

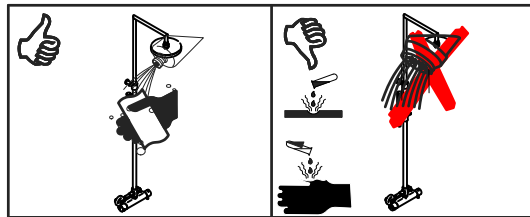

MANUTENZIONE E PULIZIA

Per una corretta manutenzione e pulizia di questo prodotto, raccomandiamo alcuni semplici accorgimenti:

- Utilizzare **detergenti neutri**, spruzzando il prodotto direttamente su un panno morbido onde evitare infiltrazioni
 - Evitare **sempre** il contatto con prodotti acidi o abrasivi
 - **Risciacquare bene** con abbondante acqua per eliminare eventuali residui ed **asciugare sempre** con un panno morbido
 - Effettuare una **pulizia periodica** al fine di prevenire le formazioni calcaree
- La BELLOSTA CARLO & C. non è RESPONSABILE di danni derivati dall'utilizzo di prodotti impropri per la pulizia.

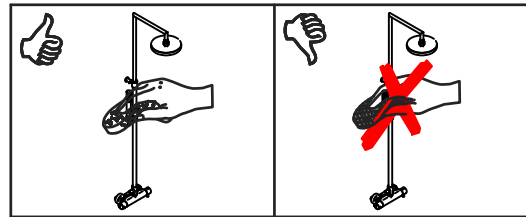

MAINTENANCE AND CLEANING

For a proper maintenance and cleaning, we recommend the following:

- Use **neutral detergents**, avoiding to spray directly on taps to avoid residual infiltration
- **Avoid** contact with acid or abrasive products
- **Rinse** with water and **always dry** with a clean cloth to avoid residue of detergent
- Perform a **periodic cleaning** to prevent limestone deposits

BELLOSTA CARLO & C. cannot be held responsible for damages due to an improper use of detergents

MADE IN ITALY

DESIGN
EQB

MADE IN ITALY

This product has been entirely manufactured in Italy, by top quality raw materials.



D

Per installatore: Al fine di garantire la durata del prodotto installare rubinetti con filtro da pulire periodicamente. Effettuare risciacquo delle tubazioni prima di installare il prodotto (PUNTO 1)
Eventuali residui se finissero all'interno della cartuccia potrebbero causarne il danneggiamento
For installer: In order to guarantee a long duration of the product install valves with filter, which have to be regularly cleaned (POINT 1). Carry out the rinsing of the pipes before install the tap.
Some external materials may damage the cadrige if not removed before the installation.

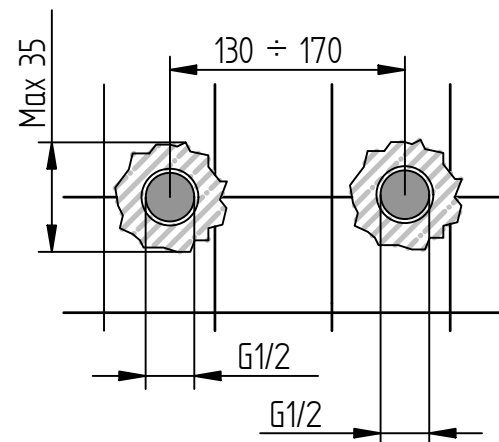

1 IMPORTANTISSIMO



A

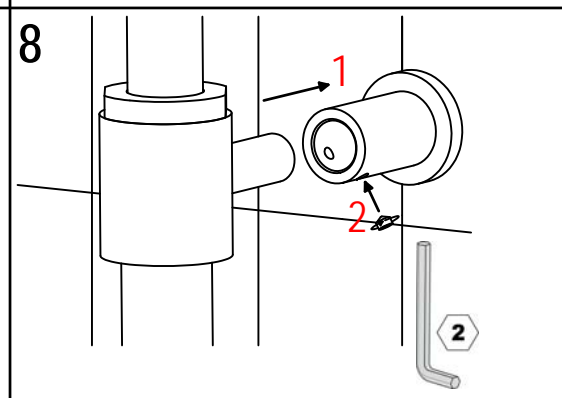
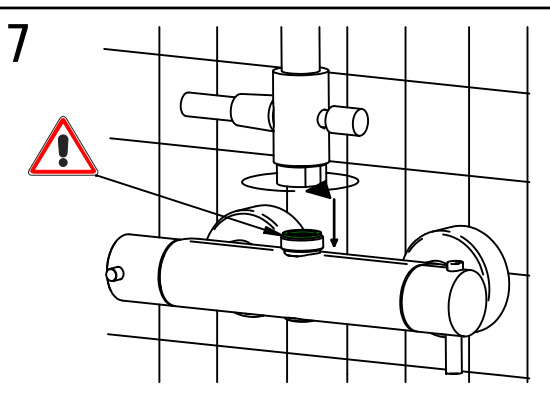
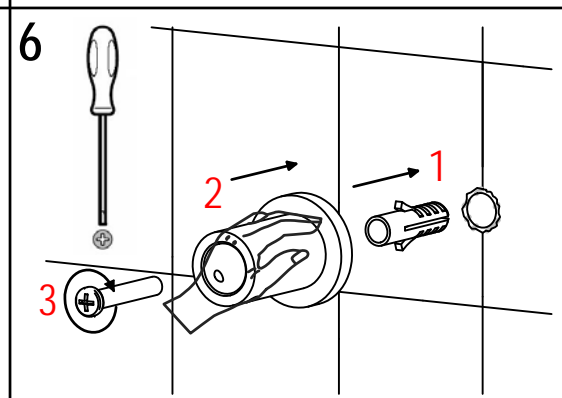
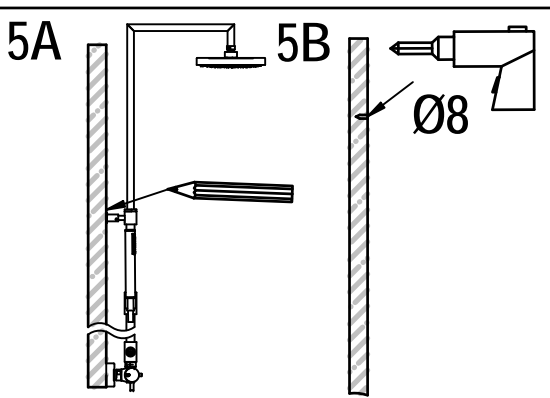
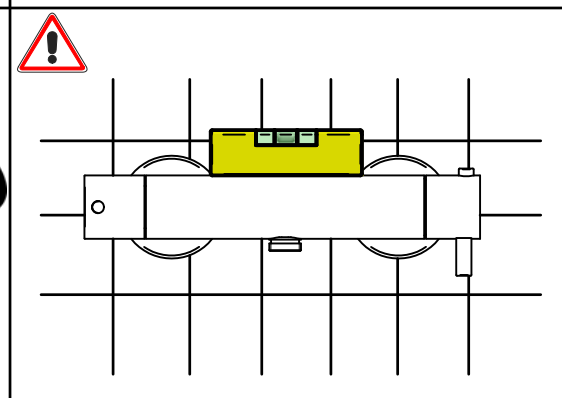
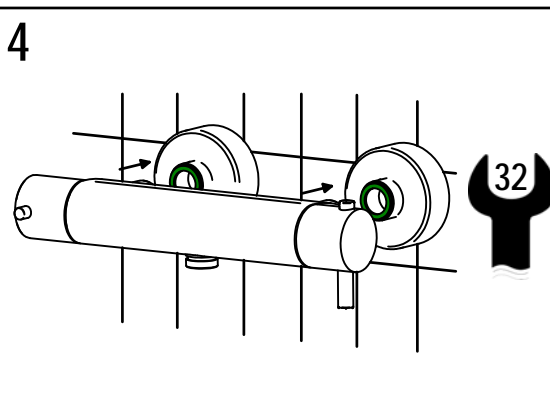
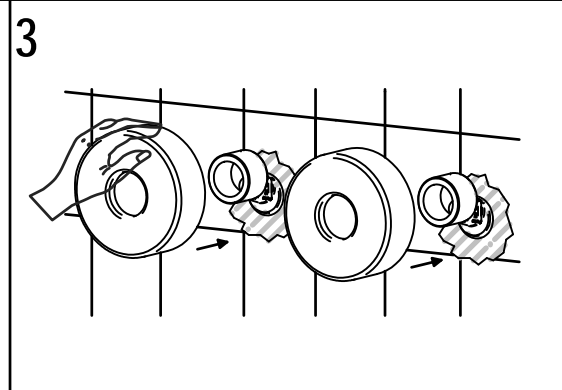
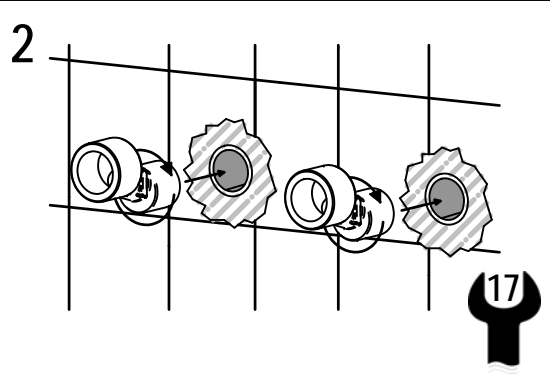

! SOSTITUZIONE CARTUCCIA / CARTRIDGE REPLACEMENT

Prima di iniziare le operazioni di sostituzione della cartuccia assicurarsi che l'acqua dell'impianto principale sia chiusa e che la cartuccia sia svuotata da residui di acqua.

Before starting replacement of cartridge, ensure that water system has been turned off and empty remaining water.

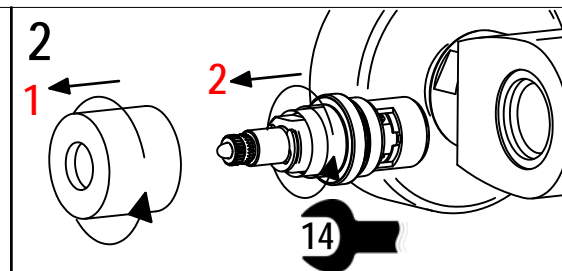

! PULIZIA/SOSTITUZIONE CARTUCCIA TERMOSTATICA

Prima di iniziare le operazioni di sostituzione della cartuccia assicurarsi che l'acqua dell'impianto principale sia chiusa e che la cartuccia sia svuotata da residui di acqua.

THERMOSTAIC VALVE CLEANING AND REPLACEMENT

Before starting replacement of cartridge, ensure that water system has been turned off and empty remaining water.

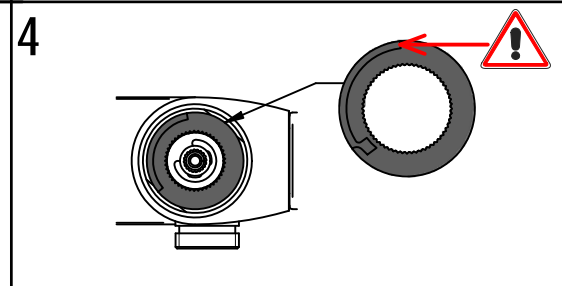
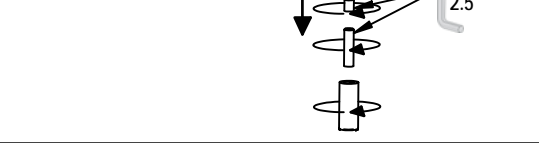

i DATI TECNICI / TECHNICAL DATA

- Pressione massima di esercizio : 5bar
- Pressione minima senza resistenza : 0.5bar
- Pressione raccomandata : 2-4bar (3ottimale)
- Blocco sicurezza 38°C, tarato in fabbrica a 3bar. Per pressioni superiori 5bar si raccomanda riduttore di pressione, in presenza di acqua dura si raccomanda filtro addolcitore. Per differenze di pressione oltre i 4bar tra calda e fredda, regolare la temperatura dell'acqua ruotando l'asta cartuccia in senso orario (fredda) e in senso antiorario (calda)

- Maximum operating pressure : 5bar
- Minimum pressure without resistance : 0.5bar
- Recommended pressure : 2-4bar (3ottimale)
- Safety block 38°C, calibrated in the factory at 3bar. For pressure over 5bar, is recommended the pressure reducer. For hard water, is recommended the lime filter. For high pressure differences, over 4bar between hot and cold water, the temperature can be adjusted by turning the broached pin, anti-clockwise (hot) clockwise (cold)