

ART. 5509/1

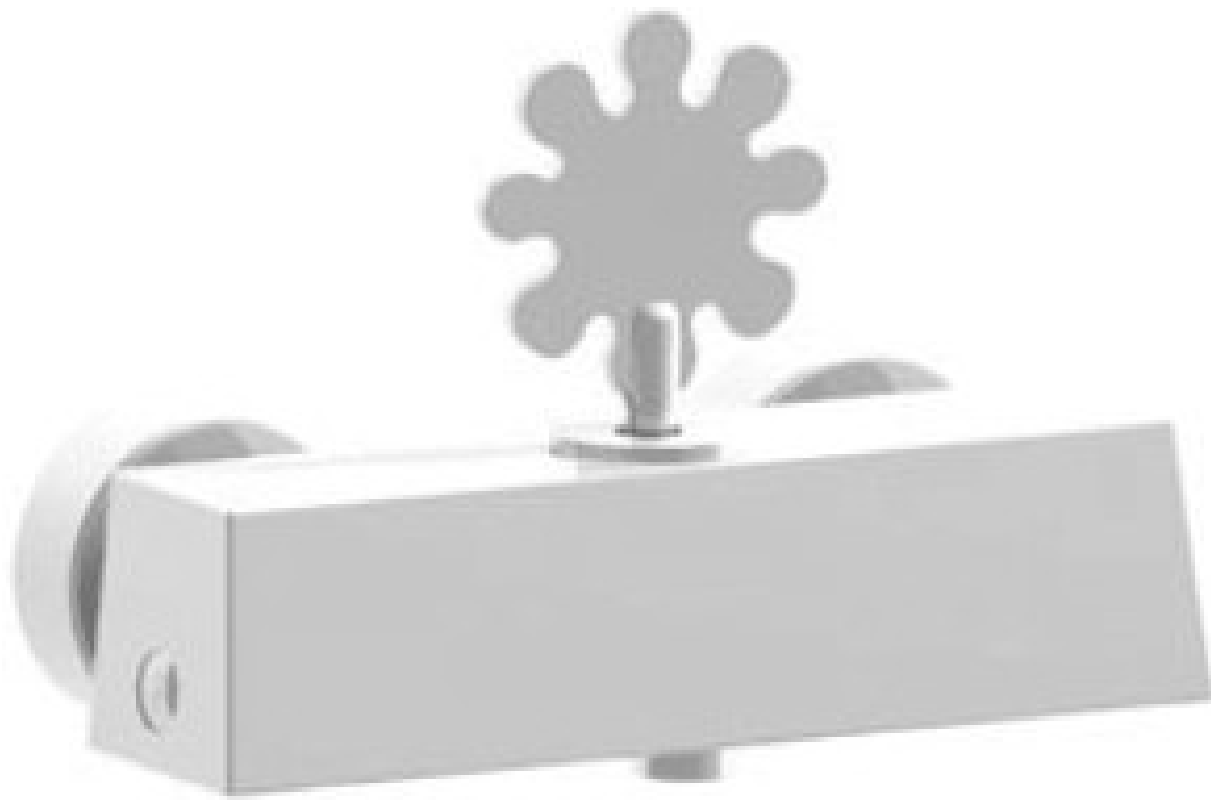

Per installatore: Al fine di garantire la durata del prodotto installare rubinetti con filtro da pulire periodicamente. Effettuare risciacquo delle tubazioni prima di installare il prodotto (PUNTO 1)

Eventuali residui se finissero all'interno della cartuccia potrebbero causarne il danneggiamento

For installer: In order to guarantee a long duration of the product install valves with filter, which have to be regularly cleaned (POINT 1). Carry out the rinsing of the pipes before install the tap.

Some external materials may damage the cadrige if not removed before the installation.

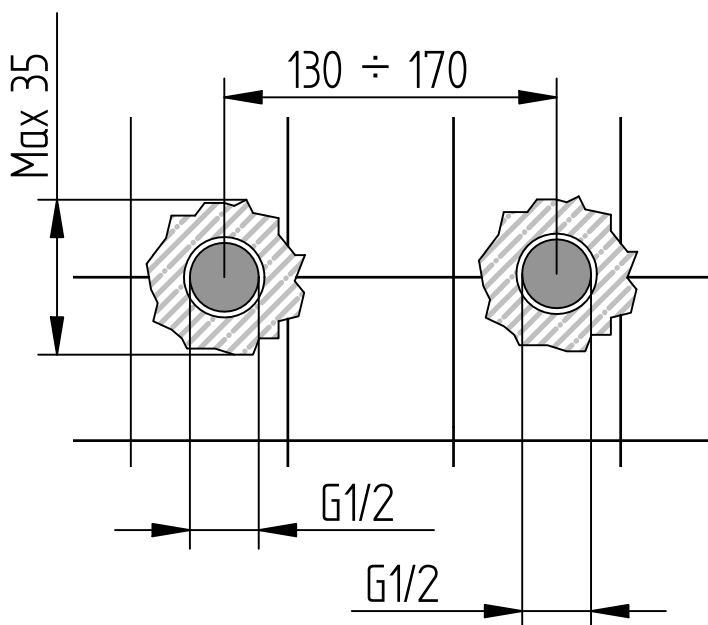

1 IMPORTANTISSIMO



2

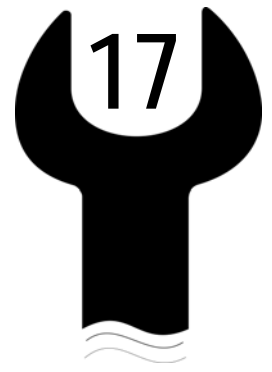
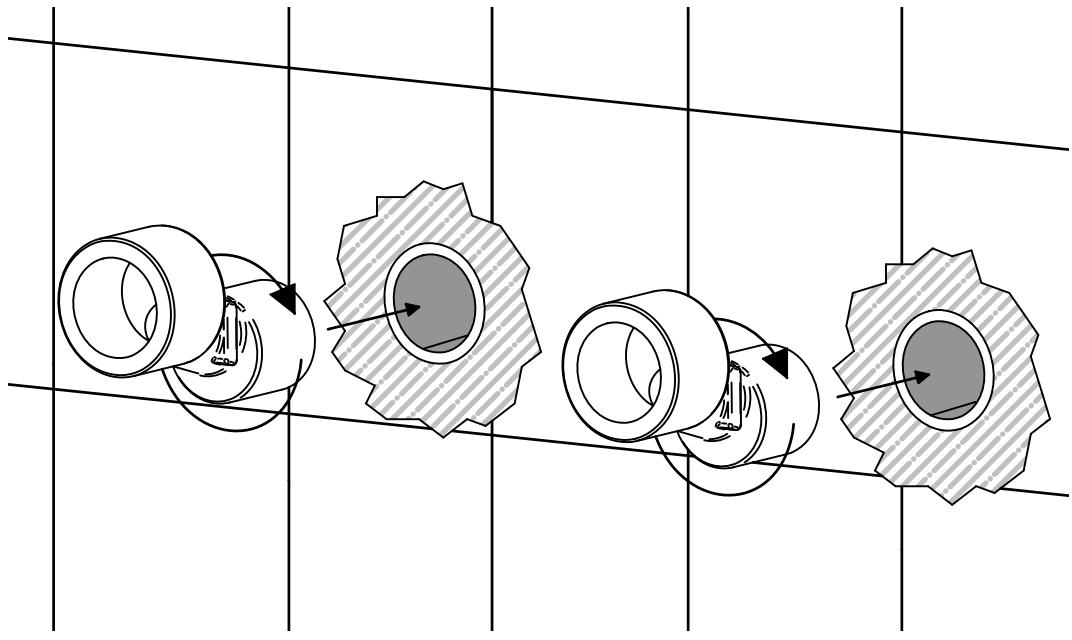

3

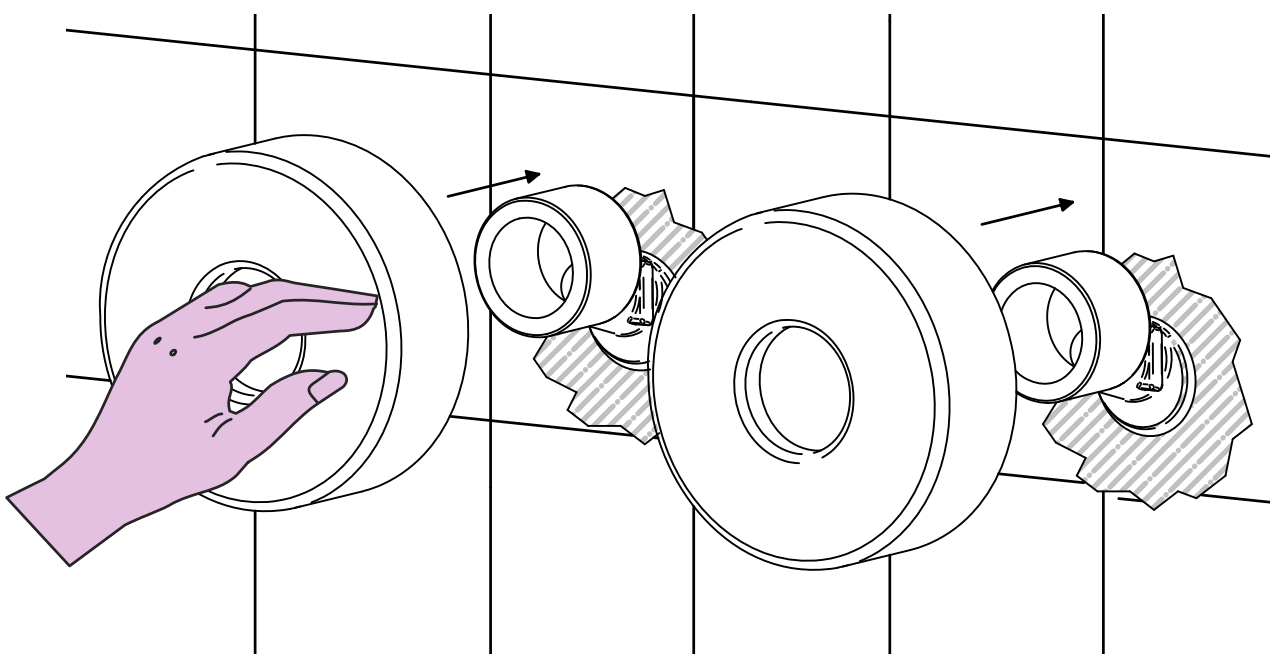

4

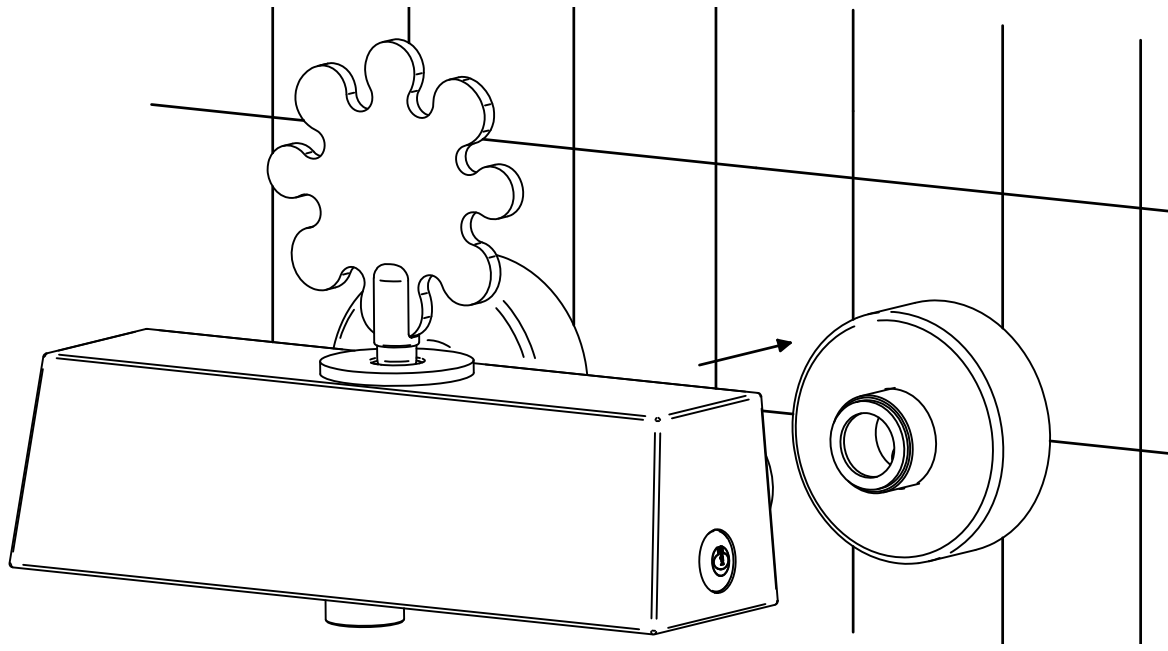



SOSTITUZIONE CARTUCCIA / CARTRIDGE REPLACEMENT

Prima di iniziare le operazioni di sostituzione della cartuccia assicurarsi che l'acqua dell'impianto principale sia chiusa e che la cartuccia sia svuotata da residui di acqua.

Before starting replacement of cartridge, ensure that water system has been turned off and empty remaining water.

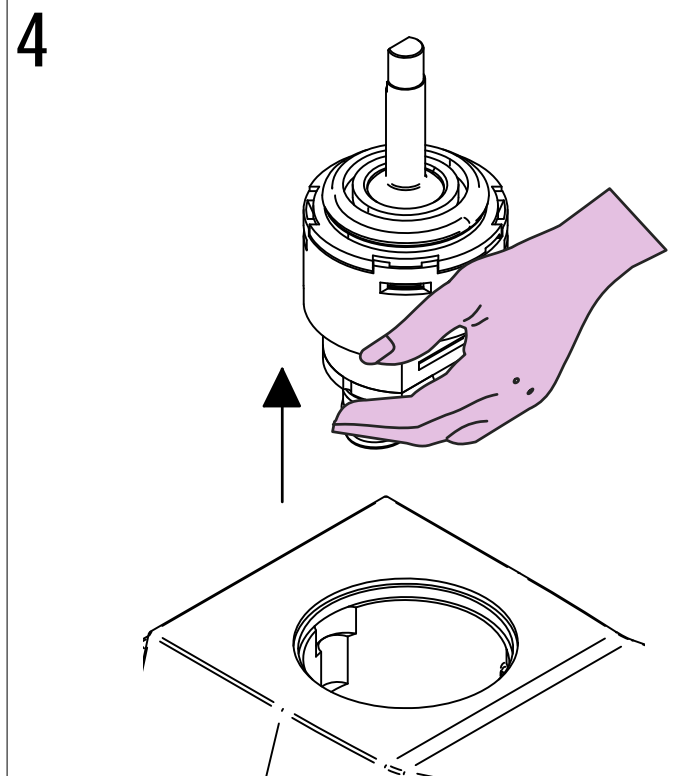
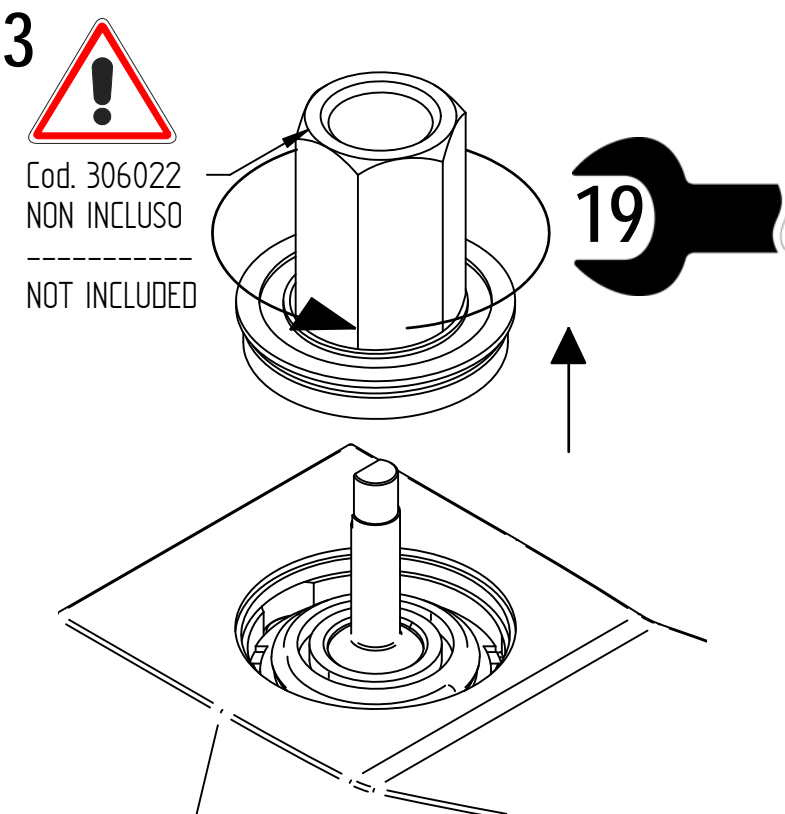
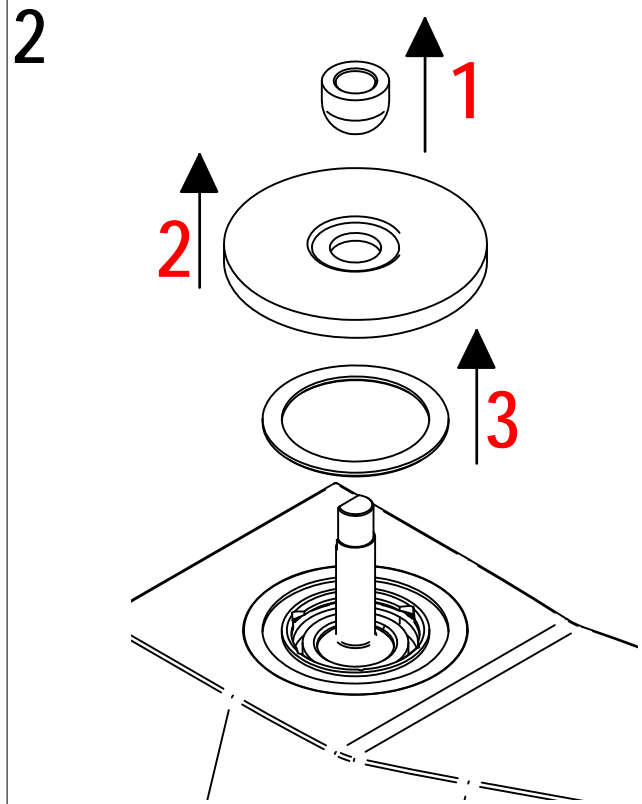
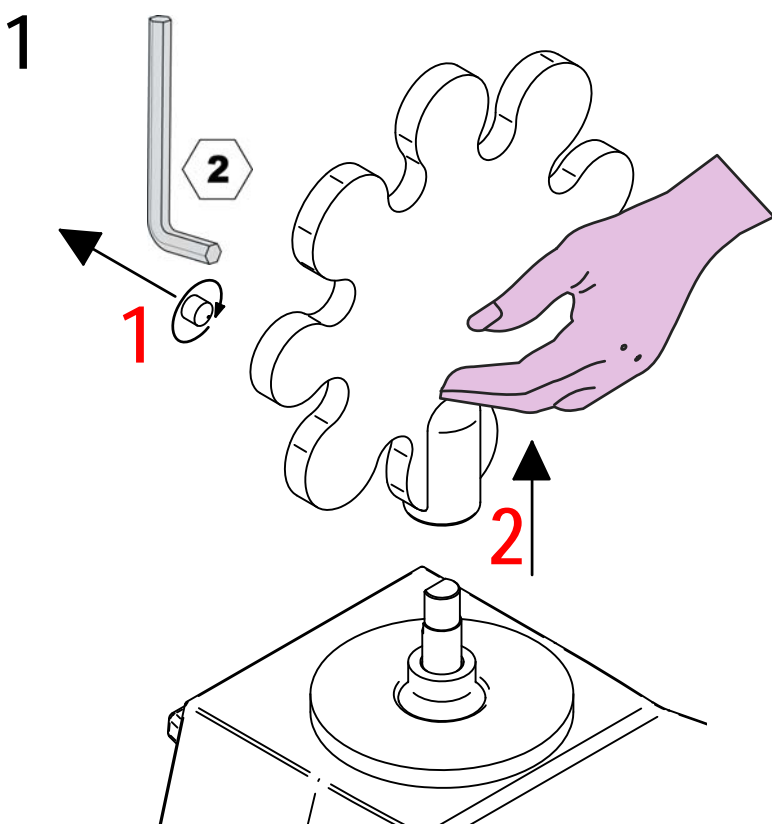

Per qualsiasi richiesta di informazioni, preghiamo contattare l'Ufficio Tecnico presso:
info@bellostarubinetterie.com
For any technical inquiries, please contact the Technical Office at: info@bellostarubinetterie.com C



RICAMBI / SPARE PARTS

Mozzo	Nuvola	Raggio	Vento	Sole	Luna
					
Inserto					
Cromo	01-554005	01-554001	01-554002	01-554003	01-554004
Wengé	01-554010-39	01-554006-39	01-554007-39	01-554008-39	01-554009-39
Palissandro	01-554010-64	01-554006-64	01-554007-64	01-554008-64	01-554009-64
Zebrano	01-554010-65	01-554006-65	01-554007-65	01-554008-65	01-554009-65

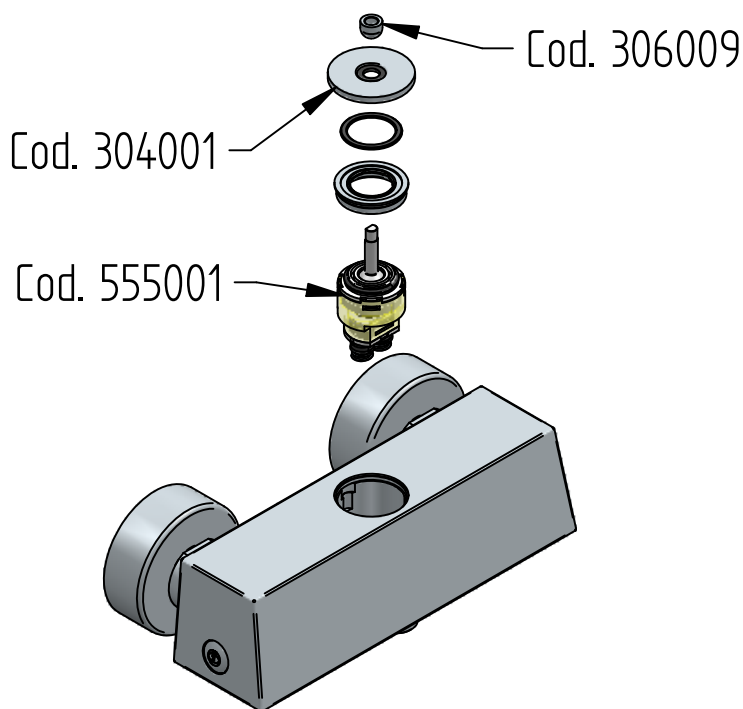

COD. 304001

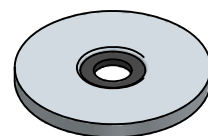

COD. 306009



COD. 555001



MANUTENZIONE E PULIZIA

Per una corretta manutenzione e pulizia di questo prodotto, raccomandiamo alcuni semplici accorgimenti:

- Utilizzare detersivi neutri, spruzzando il prodotto direttamente su un panno morbido onde evitare infiltrazioni
- Evitare sempre il contatto con prodotti acidi o abrasivi
- Risciacquare bene con abbondante acqua per eliminare eventuali residui ed asciugare sempre con un panno morbido
- Effettuare una pulizia periodica al fine di prevenire le formazioni calcaree

La BELLOSTA CARLO & C. non è RESPONSABILE di danni derivati dall'utilizzo di prodotti impropri per la pulizia.

MAINTENANCE AND CLEANING

For a proper maintenance and cleaning, we recommend the following:

- Use neutral detergents, avoiding to spray directly on taps to avoid residual infiltration
- Avoid contact with acid or abrasive products
- Rinse with water and always dry with a clean cloth to avoid residue of detergent
- Perform a periodic cleaning to prevent limestone deposits

BELLOSTA CARLO & C. cannot be held responsible for damages due to an improper use of detergents

