

edward lever

Istruzioni di installazione / Installation instruction



Per installatore: Al fine di garantire la durata del prodotto installare rubinetti sottolavabo con filtro da pulire periodicamente. Effettuare risciacquo delle tubazioni prima di installare il prodotto (PUNTO 1) Eventuali residui se finissero all'interno della cartuccia potrebbero cusarne il danneggiamento

For installator: In order to guarantee a long duration of the product install angle valves with filter, which have to be regularly cleaned (POINT 1). Carry out the rinsing of the pipes before install the tap. Some external materials may damage the cadridge if not removed before installation

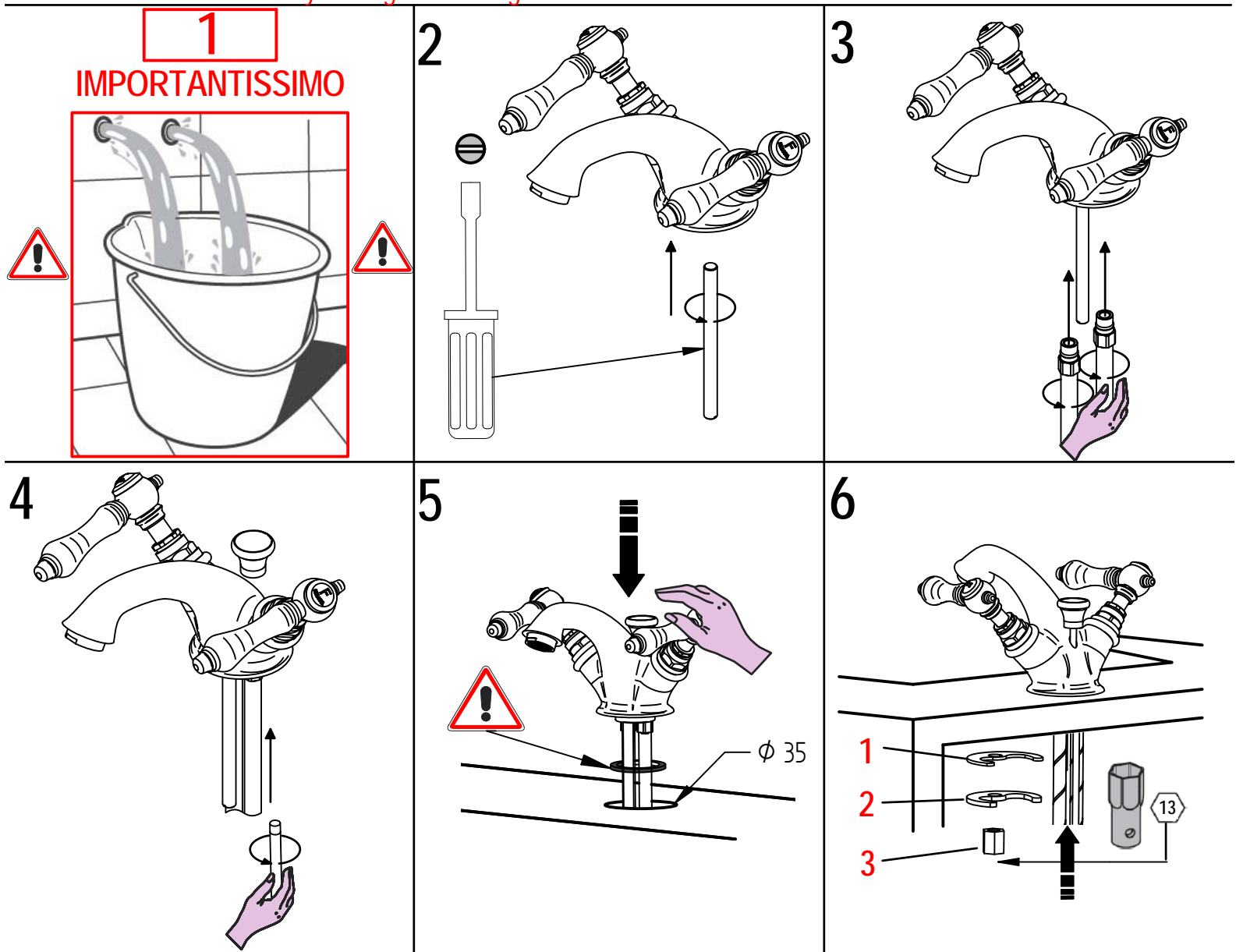

MADE IN ITALY

Questo prodotto è stato realizzato interamente in Italia con l'utilizzo di materie prime di altissima qualità

DESIGN
EQB

MADE IN ITALY

This product has been entirely manufactured in Italy, by top quality raw materials.

BELLOSTA
rubinetterie
Rubinetti d'autore Made in Italy

7

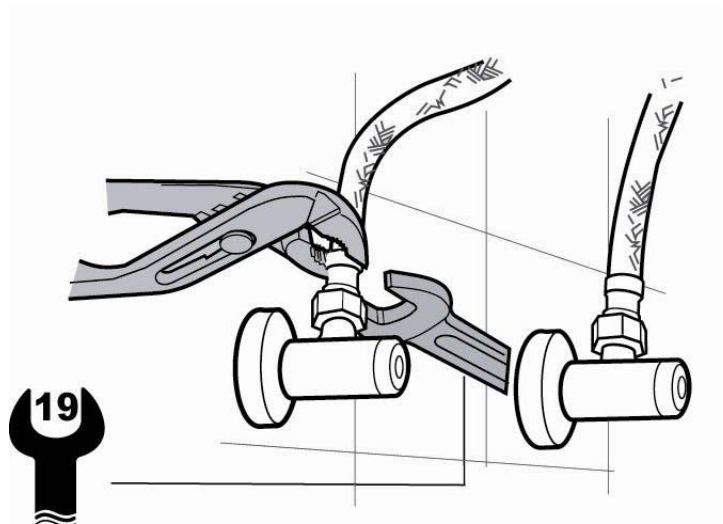

8



9

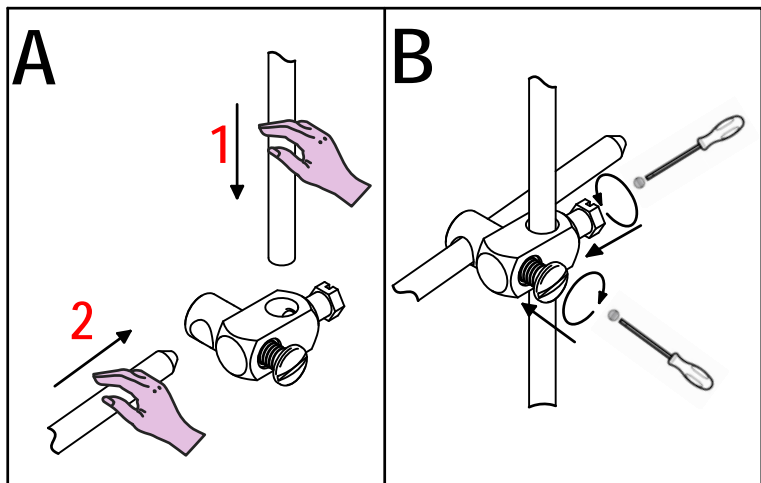

10

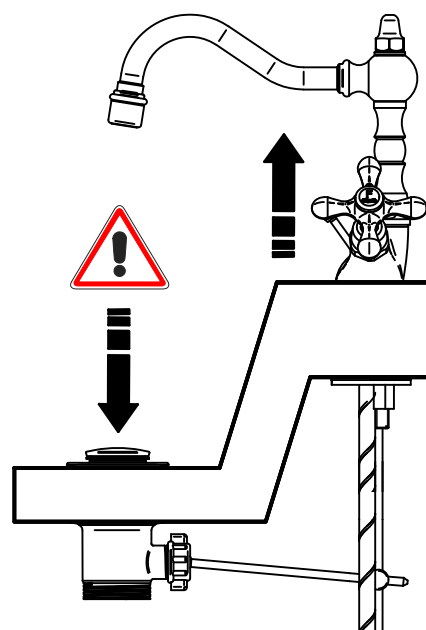

SOSTITUZIONE AERATORE / AERATOR REPLACEMENT

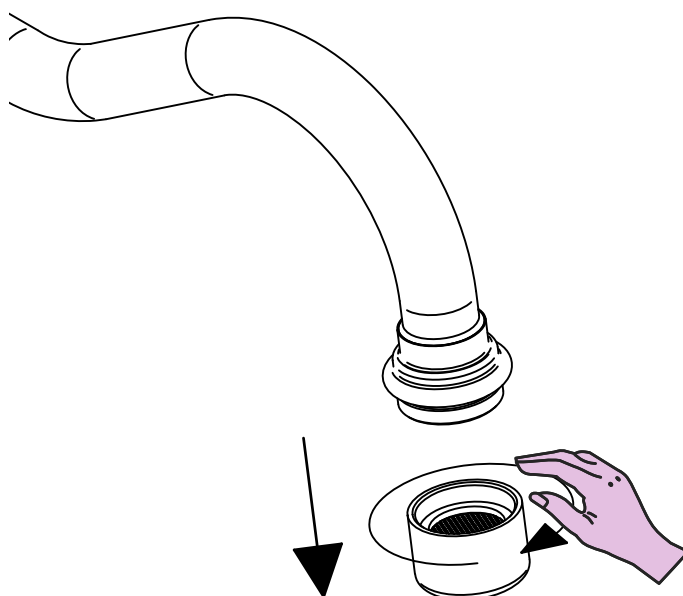

B



SOSTITUZIONE SNODINO BIDET/ JOINT BIDET REPLACEMENT

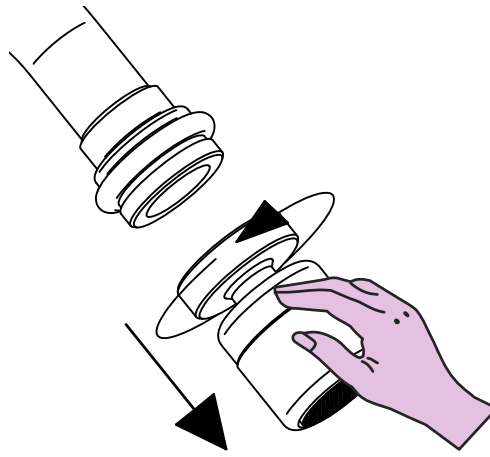

SOSTITUZIONE VITONE / VALVE REPLACEMENT

Prima di iniziare le operazioni di sostituzione del vitone assicurarsi che l'acqua dell'impianto principale sia chiusa.

Before starting replacement of the valve, ensure that water system has been turned off and empty remaining water.

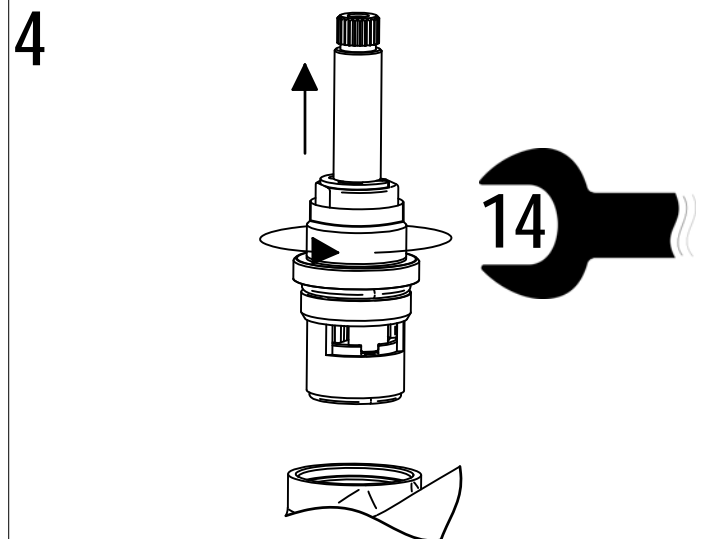
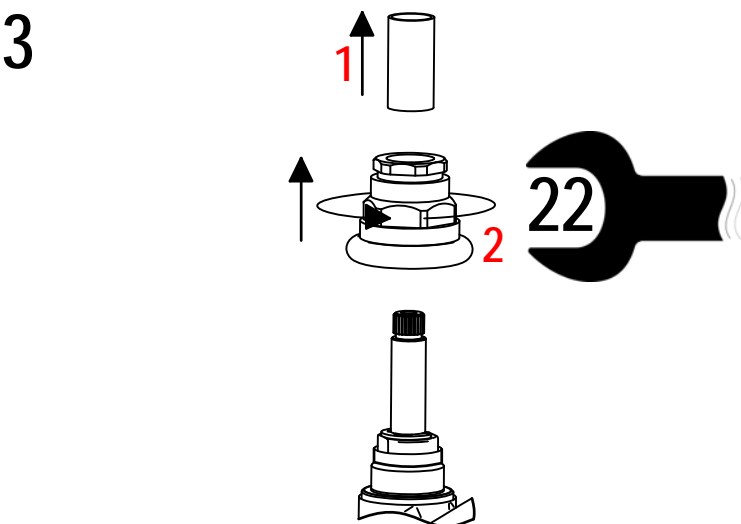
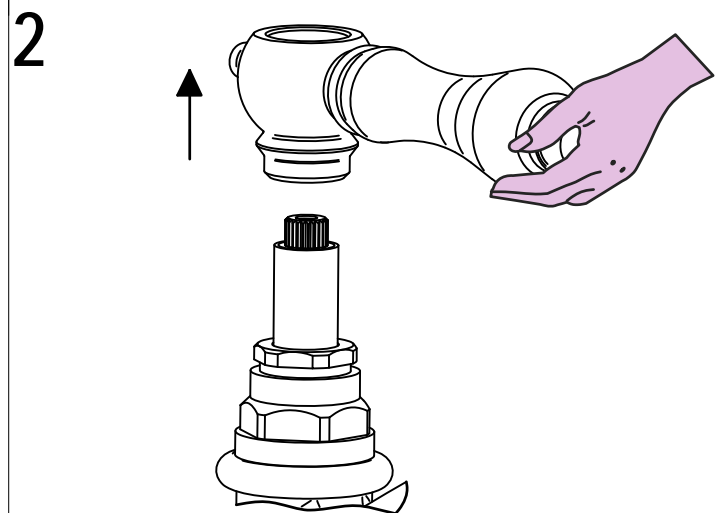
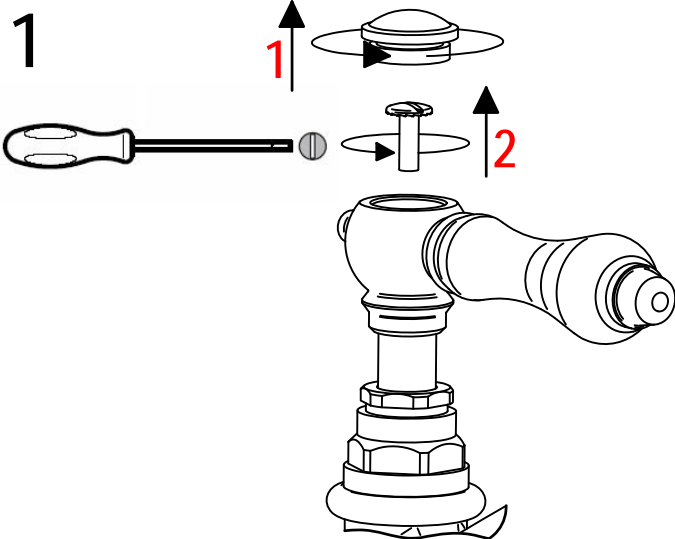



RICAMBI / SPARE PARTS

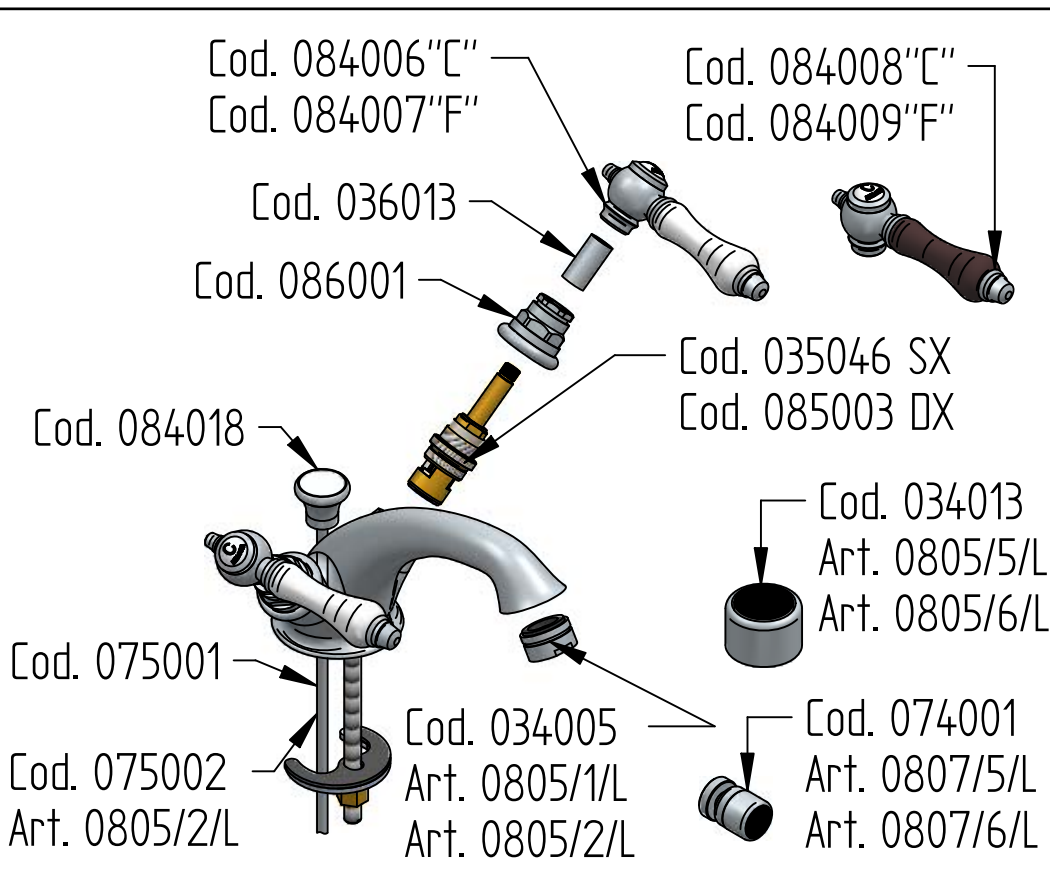

COD. 035046 COD. 085003 	COD. 084006 COD. 084007
COD. 036013 	COD. 084008 COD. 084009
COD. 086001 	COD. 084018
COD. 075001 COD. 075002 	COD. 034005

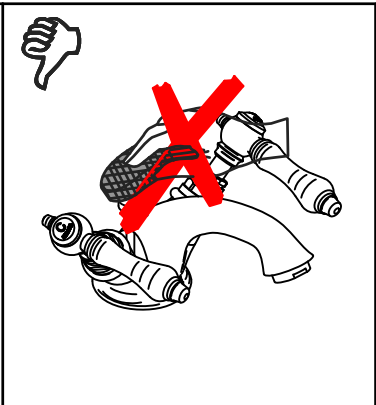
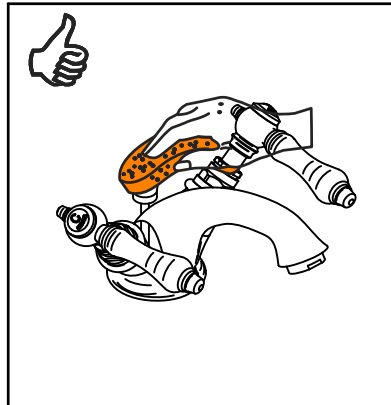
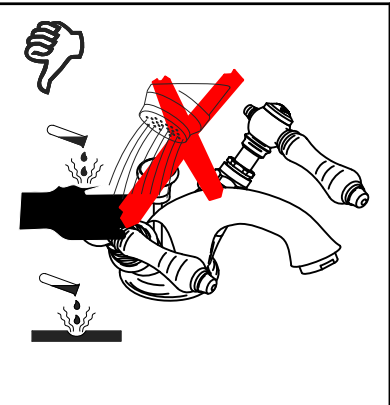
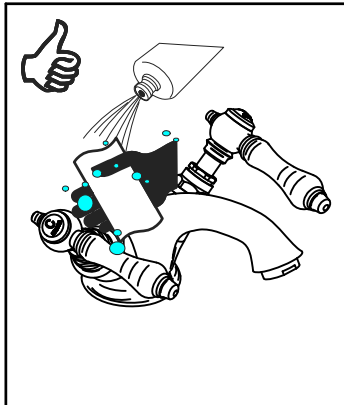

MANUTENZIONE E PULIZIA

Per una corretta manutenzione e pulizia di questo prodotto, raccomandiamo alcuni semplici accorgimenti:

- Utilizzare detergenti neutri, spruzzando il prodotto direttamente su un panno morbido onde evitare infiltrazioni
- Evitare sempre il contatto con prodotti acidi o abrasivi
- Risciacquare bene con abbondante acqua per eliminare eventuali residui ed asciugare sempre con un panno morbido
- Effettuare una pulizia periodica al fine di prevenire le formazioni calcaree

La BELLOSTA CARLO & C. non è RESPONSABILE di danni derivati dall'utilizzo di prodotti impropri per la pulizia.

MAINTENANCE AND CLEANING

For a proper maintenance and cleaning, we recommend the following:

- Use neutral detergents, avoiding to spray directly on taps to avoid residual infiltration
- Avoid contact with acid or abrasive products
- Rinse with water and always dry with a clean cloth to avoid residue of detergent
- Perform a periodic cleaning to prevent limestone deposits

BELLOSTA CARLO & C. cannot be held responsible for damages due to an improper use of detergents

